

# THE MARK FOUR

A contractor's dream come true

**Henderson**



# THE MARK FOUR

Versatility-plus

## The MARK FOUR is everything you want it to be.

If ever there was a contractor dump body that defined versatility, this is it. While the Mark Four is built in the tradition of the Henderson Mark Series, we've added a few "goodies" to make it downright *ambidextrous*.

Our new split drop-side option opens up new vistas for the contractor. Drop only half (front or rear) of either side, or the entire side, and you have total control of the cargo for ease of loading and unloading. Or, of course, just plain dump it. The choice is yours. Add the option of sloped steel side boards (fixed side model only) and the capacity increases by almost 100 percent. The 8" mounting height provides the ultimate in stability and further increases ease of cargo handling.

The MARK FOUR is built rugged so it won't get ragged. Proven Mark Series features are standard. Features like: cross-memberless underbody to prevent washboarding; unibody design with one-piece bottom and sides joined with a continuous weld 2" radius for added strength; double-walled sides and tailgate for extra rigidity; trunnion-mounted telescopic hoist for tremendous lifting power; and many more shown here.

Yet, with all of this durability, you get styling that will enhance your company image. Because your rolling stock is your image. The flowing horizontal lines presented by the Mark Four's self-cleaning rails give it a sleek look. It's a traveling billboard that will present your company in a positive manner.

The MARK FOUR is a contractor's dream come true. See your Henderson dealer and get rid of your hauling nightmares. Only from...

*The Dependable Ones*



OPTIONAL: Split drop-sides add versatility of cargo handling from all sides. The complete side drops down or just the forward or aft sections on either side. A positive-latching system bonds the sections together for strength and rigidity when hauling dirt, gravel, sand and rubble. Sloped edges on the floor and side panels make them self-cleaning for easy closing.



OPTIONAL cab shield has a streamlined design that keeps cargo in its place.



OPTIONAL headsheet windows are available for driver and/or passenger side. Provides full view of the load and back-up visibility while protecting the cab window.

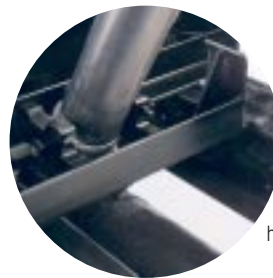

The nitrided, trunnion-mounted telescopic hoist provides greater lift capacity and faster cycle time. Also lowers mounting height for easier cargo handling.

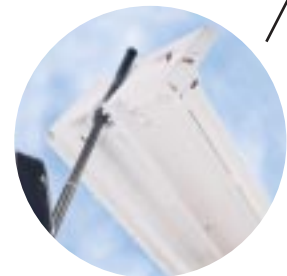

Eight-inch structural I-beam longitudinals eliminate the need for cross-members, resulting in a smooth under-structure that does away with washboarding and material hang-ups.

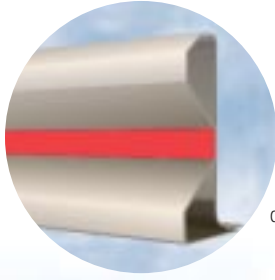

Double-walled sides are tied to full-depth corner posts for a rugged body that resists damage. All bracing is sloped outward to shed dirt and debris.

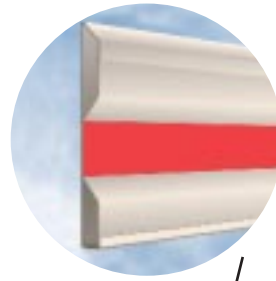

Double-acting tailgate has 10-gauge double-wall construction and full-perimeter boxing. Rails are sloped to shed debris. Flame-cut steel tailgate latches are mounted to steel plates that overlap the rear corner posts and apron, preventing spreading of sides.



Heavy-duty offset hinge plates are integrated with flush-mounted hardware to provide a strong, streamlined tailgate pivot with easy-handling pins.

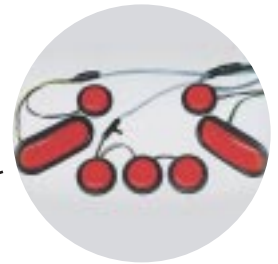

Shock resistant stop/turn/tail lights and I.C.C. light cluster are provided with a sealed one-piece harness that connects directly to the truck electrical system.



The unibody design features a one piece 3/16" high-tensile strength floor continuous seam welded to 12-gauge sides. A 2" floor-to-side radius eliminates load hang-up. (Optional sideboards shown)

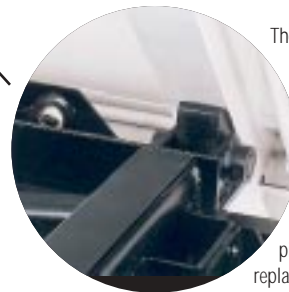

The rear hinge assembly is constructed using a 6" x 4" x 3/8" structural angle for superior resistance to twisting. Stainless steel 1-1/2" diameter pins connect through 2-1/2" hinge blocks using greaseless composite bushings for a tight fit, reducing body sway and increasing stability. Bushings and pins provide years of service without replacement.



Full-depth rear corner posts are tied to 5" structural channel rear apron and have built-in stop/turn/tail lights. Built-in sideboard pockets are standard.

# SPECIFICATIONS

## MARK FOUR DIMENSIONS AND CAPACITY CHART

Length	WIDTH		HEIGHT			CAPACITY		HOIST			
	Inside	Outside	Side	Tailgate	Head	Sides/Ends (Cubic Yards)	w/Sideboards (Cubic Yards)	Type Class	Class	Rated Capacity (NTEA) Tons @ the Critical Angle	Capacity Tons @ Lutoff
12'	85"	96"	13"	19"	50"	3.4/4.9	8.9	M110-4.5-3	60	17.3 @ 40.4°	30.2
14'	85"	96"	13"	19"	50"	4.0/5.7	10.4	M130-4.5-3	60	13.6 @ 33.7°	29.9
16'	85"	96"	13"	19"	50"	4.5/6.6	11.9	M130-4.5-3	60	12.0 @ 29.0°*	29.8

\* Specifications subject to change without notice

\* NTEA dump angle rating is 50° Mark Four 16ft. body is 44°

### UNIBODY DESIGN

- One-piece floor and side sheets joined by 2" radius.
- Full-depth corner posts tied to 5" structural steel channel rear apron.
- Smooth understructure has 8" structural steel I-beam longitudinals with no cross-members and a low 8" mounting height.

### HOIST

- Trunnion-mounted, bore-sealed design (not an inverted cylinder).
- Nitrided cylinder tubes — nitriding process increases wear and corrosion resistance. The nitrided layer is part of the cylinder material.
- Two year cylinder warranty.

### MOUNTING

- Low 8" mounting height.
- Modular cradle and rear hinge assembly for quick installation.

### FLOOR

- One-piece 3/16" high-tensile steel.
- 8" x 13.0 lbs./ft. I-beam sills with no cross-members.
- 50,000 PSI minimum yield strength.

### SIDES

- Double-wall 12-gauge construction.
- Continuous welded to full height corner posts.
- 2" formed floor-to-side radius.
- Sloped top and bottom rail.

### HEADSHEET

- 12-gauge sheet.
- Small doghouse — 12" deep x 11" wide.
- Extra tall for side board support.

### TAILGATE

- Double-wall 10-gauge construction.
- One-piece sheet with full-perimeter boxing and sloped top, bottom rails.
- Flush-mount, offset tailgate hinge plates with easy-release pins.
- 1" top and 1-1/4" bottom latch pins.
- Manual over-center tailgate release mechanism with rubber covered handle.

### LIGHT PACKAGE

- Stop/turn/tail lights are recessed in rear corner posts.
- I.C.C. and rear clearance lights with reflectors are also included.
- All lights are rubber mounted, shock resistant and feature one-piece sealed wiring harness.

### BODY PREPARATION

- Entire body is chemically cleaned with a phosphate solution before being primed.
- Primed with high quality urethane primer.

### OPTIONS

- Cab shield with streamlined end plates to eliminate sharp edges.
- One or two headsheet windows provide visibility and protect cab window.
- One-piece 12-gauge sloping side boards (Fixed sides only).
- Split drop-down sides feature self-cleaning design.
- Coal chute.
- L.E.D. Light Kit.



Almost double capacity with these sloping side boards. They are constructed of one-piece 12-gauge steel with 10-gauge top rail to take a real beating without yielding. Though they're tough, they are easy to install into built-in board pockets.

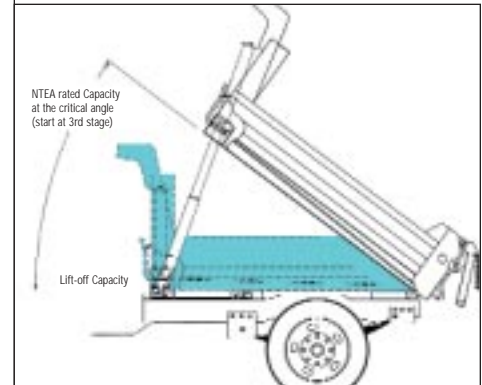

Illustrated above are the NTEA Capacity and Lift-off Capacity points of measure for the hoist data shown in the chart above.



P.O. Box 40 • Manchester, Iowa 52057  
800-359-4970 • www.henderson-mfg.com